



AURALED



www.auraled.co.uk

Road & Street Lighting Fixtures

## SENTOR ST



RAL 7037

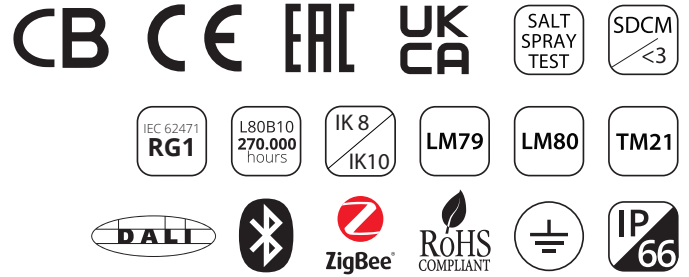
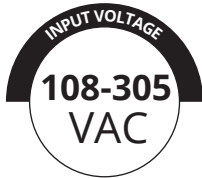

### Specifications

- IP66 protection
- Aluminium injection body
- Engineered to operate in harsh and hot conditions
- Over **60.000** hours life according to LM80 and TM21 standard
- Up to **153+ lm/W** efficiency
- Input voltage range: **108-305VAC** against voltage fluctuation
- **10kV** surge protection
- **-40°C / +55°C** operating temperature
- Aluminum PCB (2,0 W/mK)
- SMD PCB connector
- Special silicone gasket
- Brass cable gland and brass ventilation valve
- Options for catenary, park/garden, road/street applications
- Measurements according to EN 60598-1 standards
- Photometric measurements according to IESNA-LM-79-08

### Application Areas

- Park & Garden Lighting
- Street Lighting

### Optional

- Marine protective coating
- 5 and 7 pins NEMA socket options
- Sensor, dimming, wireless communication features
- I-10V, DALI automation integration

### Beam Angles

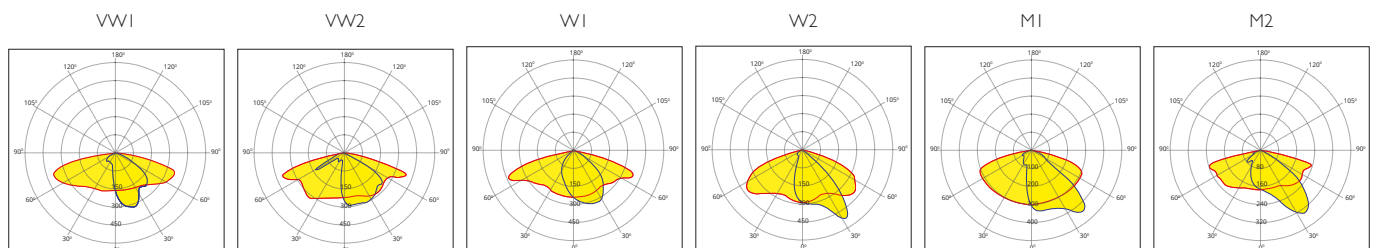



Dimensions

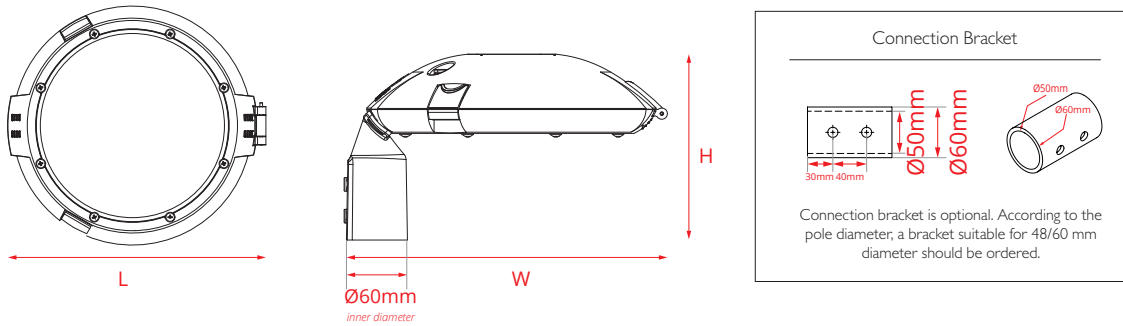

Mounting Options

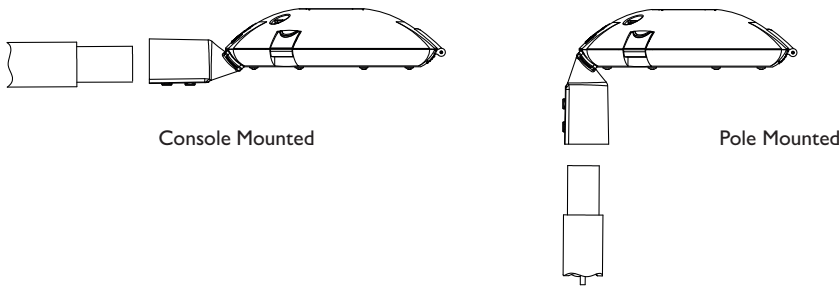

Product Photos

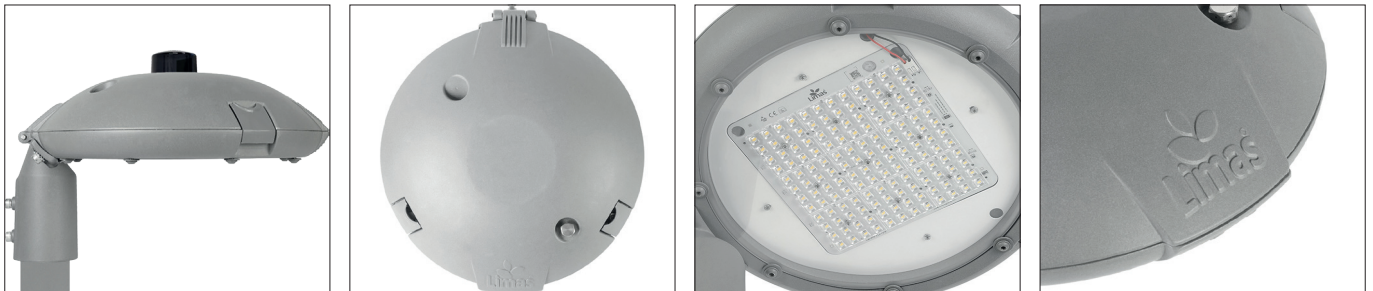

Sentor ST

	W	lm	lm/W	LED	▲	K	AC	CRI	IP	L (mm)	W (mm)	H (mm)	gr
AL-SENTOR ST 51	51	7811	153	NICHIA / LUMILEDS SEOUL	M1	4000	108-305VAC	>70	IP66	350	407	234	6500
AL-SENTOR ST 65	65	9625	148	NICHIA / LUMILEDS SEOUL	M1	4000	108-305VAC	>70	IP66	350	407	234	6500
AL-SENTOR ST 80	80	11469	143	NICHIA / LUMILEDS SEOUL	M1	4000	108-305VAC	>70	IP66	350	407	234	6500

Power and lumen values are within ± 5% tolerance

Lumen Multiplier Table

CRI	3000K	4000K	5000K	6500K
70	0,95	1,00	1,00	0,97
80	0,88	0,95	0,95	0,93
90	0,75	0,80	0,80	0,80